

EE 435

Lecture 12

Other Gain Enhancement Strategies

- Cascaded Amplifiers

OTA Applications

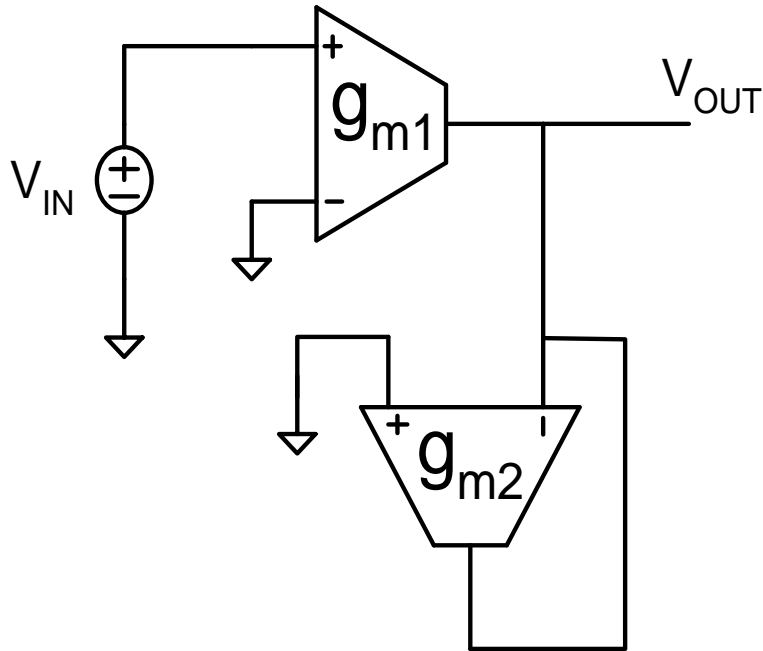

$$V_{\text{OUT}} = \frac{g_{m1}}{g_{m2}} V_{\text{in}}$$

Noninverting Voltage Controlled Amplifier

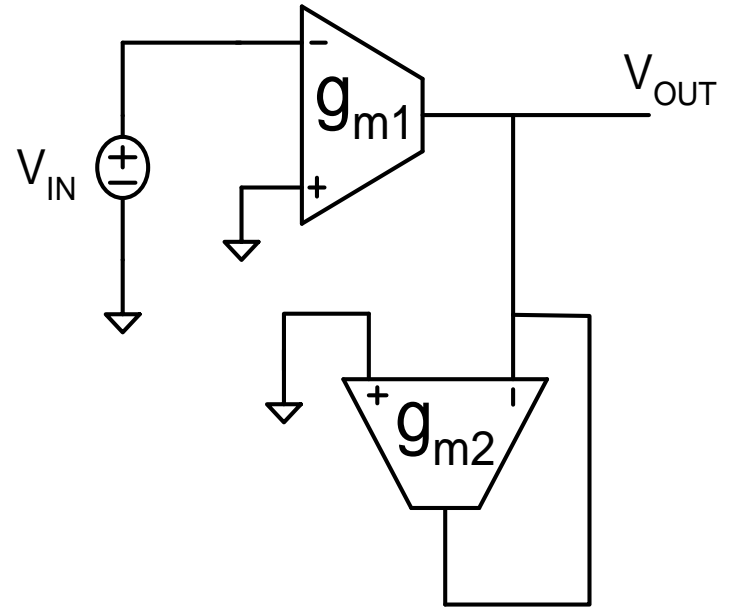

$$V_{\text{OUT}} = -\frac{g_{m1}}{g_{m2}} V_{\text{in}}$$

Inverting Voltage Controlled Amplifier

Extremely large gain adjustment is possible

Voltage Controlled Resistorless Amplifiers

Comparison of Current-Mirror Op Amps with Previous Structures

Does the simple mirror gain really provide an “almost free” gain enhancement ?

$$A_{VO} = -\frac{M \bullet \frac{g_{m1}}{2}}{g_{O6} + g_{O8}}$$

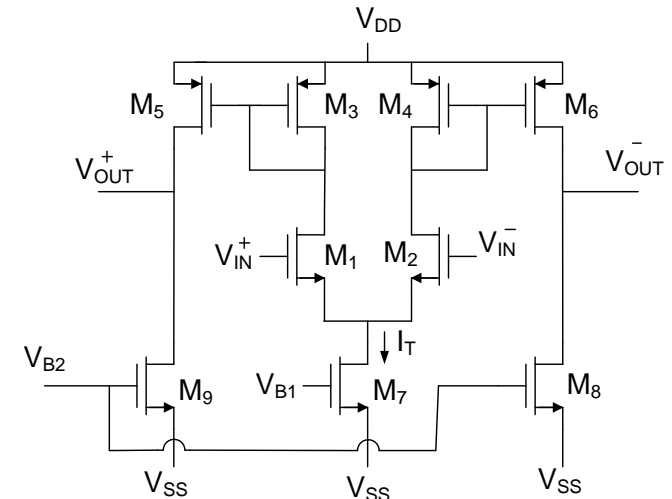

Consider how the gain appears in the practical parameter domain

$$A_{VO} = \frac{\frac{1}{2} \left(2 \frac{I_T}{2} M \right)}{V_{EB1} (\lambda_{M6} + \lambda_{M8}) I_{D8Q}} = \frac{\frac{I_T}{2} M}{V_{EB1} (\lambda_{M6} + \lambda_{M8}) M \frac{I_T}{2}} = \frac{1}{V_{EB1} (\lambda_{M6} + \lambda_{M8})} \cong \frac{1}{2\lambda V_{EB1}}$$

This is exactly the same as was obtained for the simple differential amplifier!

For a given V_{EB1} , there is NO gain enhancement !

Comparison of Current-Mirror Op Amps with Previous Structures

How does the SR compare with previous amplifiers ?

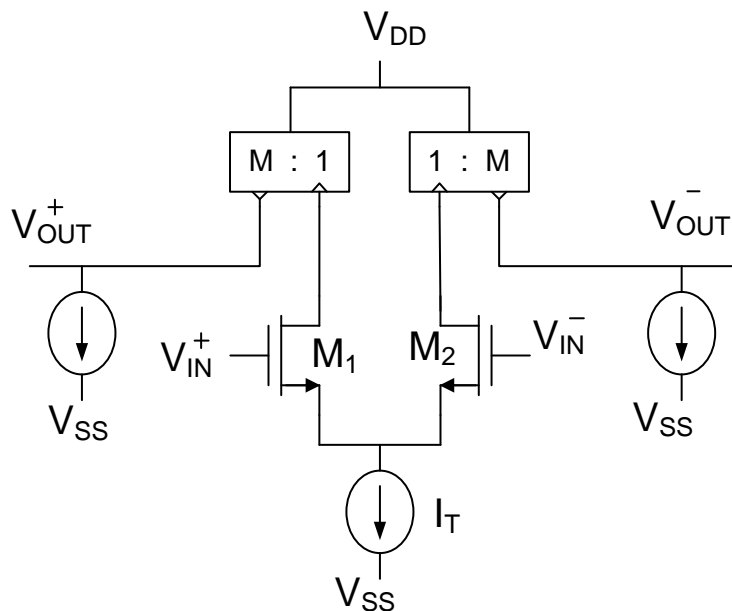

$$SR_{\text{Ref Op Amp}} = \frac{I_T}{2C_L}$$

$$SR = \frac{M \cdot I_T}{2C_L}$$

SR Improved by factor of M !
but ...

$$P = V_{DD} I_T (1 + M)$$

$$SR = \frac{P}{2V_{DD} C_L} \left[\frac{M}{1 + M} \right]$$

$$SR_{\text{Ref Op Amp}} = \frac{P}{2V_{DD} C_L}$$

SR Really Less than for Ref Op Amp !!

Comparison of Current-Mirror Op Amps with Previous Structures

How does the Current Mirror Op Amp really compare with previous amplifiers or with reference amplifier?

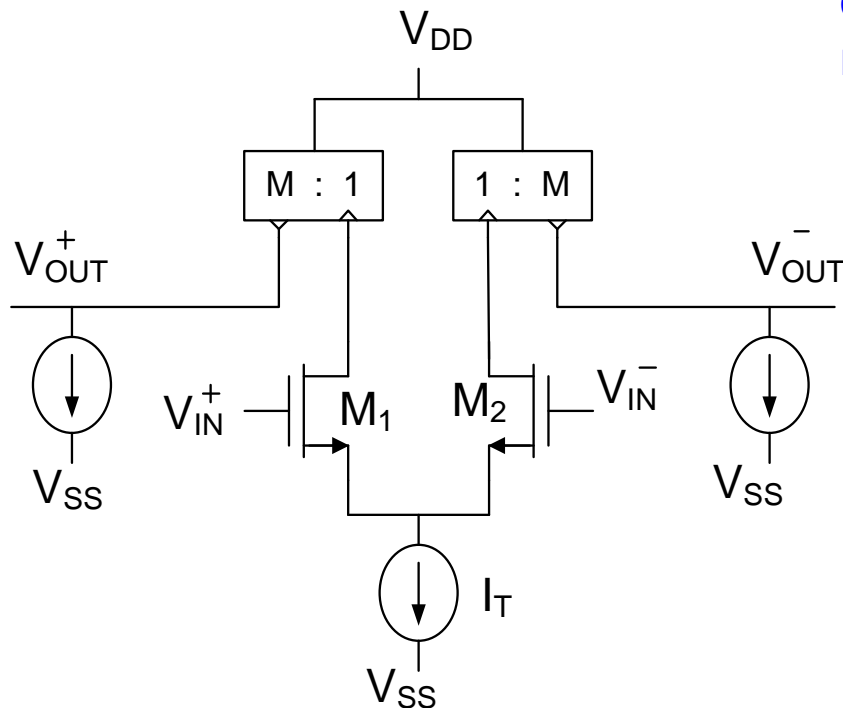

Perceived improvements may appear to be very significant

Actual performance is not as good in almost every respect !

But performance is comparable to other circuits and the circuit structure is really simple

Widely used architecture as well but maybe more for OTA applications

Amplifier Design

- Fundamental Amplifier Design Issues
- Single-Stage Low Gain Op Amps
- Single-Stage High Gain Op Amps



Other Basic Gain Enhancement Approaches

- Cascaded Amplifiers
- Two-Stage Op Amp
 - Compensation
 - Breaking the Loop
- Other Issues in Amplifier Design
- Summary Remarks

Review from Last Time

Current-Mirror Op Amps – Another Perspective !

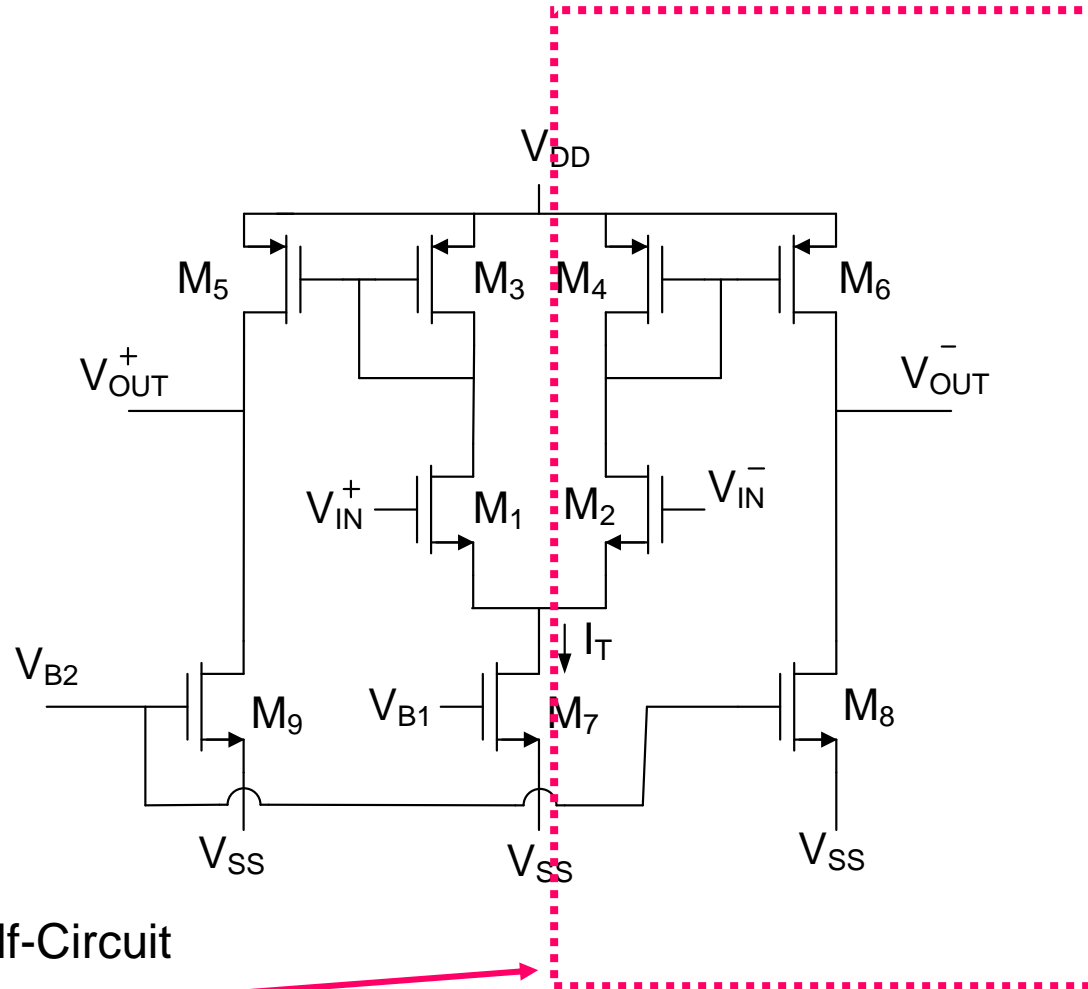

Differential Half-Circuit

Note: Source node of M_1 and M_2 at ac ground with differential excitations

Review from Last Time

Current-Mirror Op Amps – Another Perspective !

Differential Half-Circuit

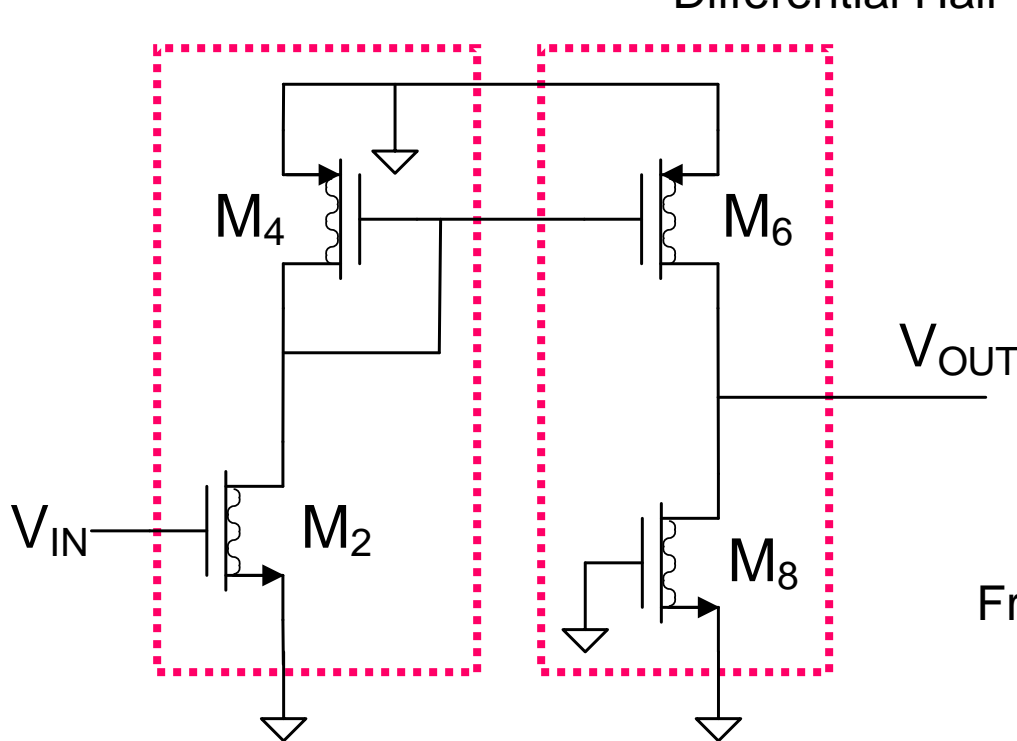

$$V_{IN} = \frac{V_d}{2}$$

$$A_{Vd} = -\frac{1}{2} \left(\frac{g_{m2}}{g_{m4}} \right) \left(\frac{g_{m6}}{g_{o6} + g_{o8}} \right)$$

From Current Mirror Analysis :

$$A_{VdO} = -\frac{M \cdot \frac{g_{m2}}{2}}{g_{o6} + g_{o8}} = -\frac{\frac{g_{m6}}{g_{m4}} \cdot \frac{g_{m2}}{2}}{g_{o6} + g_{o8}}$$

Cascade of n-channel common source amplifier with p-channel common-source amplifier !

Review from Last Time

Increasing Gain by Cascading

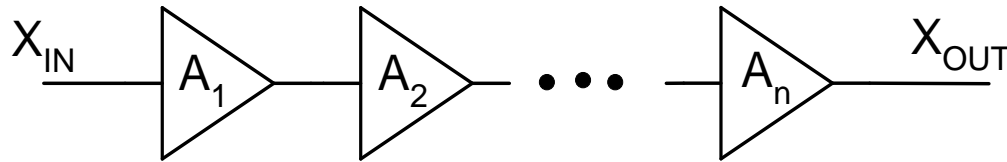

$$\frac{X_{OUT}}{X_{IN}} = A = \frac{\prod_{i=1}^n A_{oi}}{\prod_{k=1}^n \left(\frac{s}{\tilde{p}_k} + 1 \right)}$$



Dramatic improvement in performance for the open-loop amplifier !!

But – op amps seldom used open loop

How does the cascaded amplifier perform in a standard feedback application?

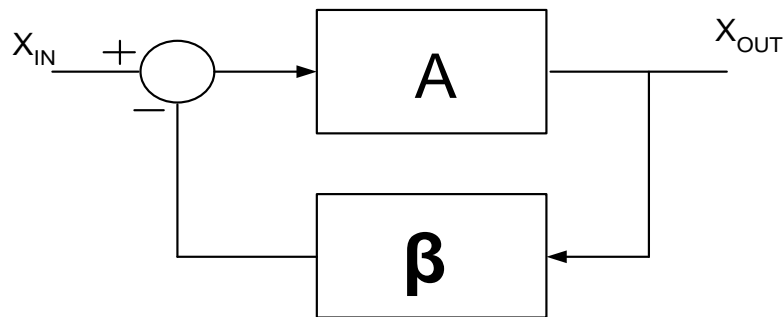

$$A_{FB} = \frac{A}{1 + A\beta}$$

Stability

- Sometimes circuits that have been designed to operate as amplifiers do not amplify a signal but rather oscillate when no input signal is present ($V_{in}=0V$ or $I_{in}=0A$) or “latch up”
- Circuits that are designed to operate as amplifiers but instead either oscillate or “latch up” are said to be unstable
- The stability of any circuit is determined by the location of the poles
- We will discuss stability with more rigor later
- It will be shown that if the poles of an open-loop amplifier are widely separated on the negative real axis, then the feedback amplifier built using the open-loop amplifier will be stable
- And, it will be shown that if the poles of an open-loop amplifier are not widely separated on the negative real axis, then the feedback amplifier built using the open-loop amplifier will be unstable

Poles of an Amplifier

- The poles of an amplifier are the roots of the denominator of the transfer function
- Each energy storage element (capacitor or inductor) introduces an additional pole (except when capacitor or inductor loops exist)
- The poles of an amplifier can often be approximated by independently considering the impedance facing each capacitor and assuming all other capacitors are either open circuits or short circuits

Poles of an Amplifier

- The dead network of a circuit is obtained by setting all independent sources to zero
- The poles of a circuit are absolute: That is, they are independent of where the excitation is applied or where the response is taken provided the dead networks are the same!
- Stability is absolute: That is, a circuit is either stable or unstable irrespective of where the input is applied or the response is taken provided the dead networks are the same

Review from Last Time

Increasing Gain by Cascading

Provided the stages are non-interacting

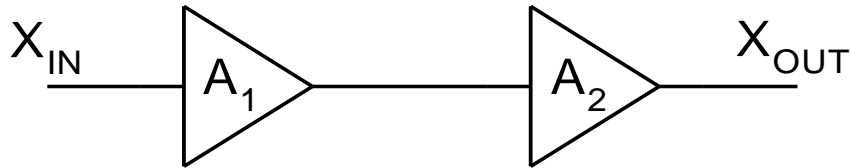

$$\frac{X_{OUT}}{X_{IN}} = A_1 A_2$$

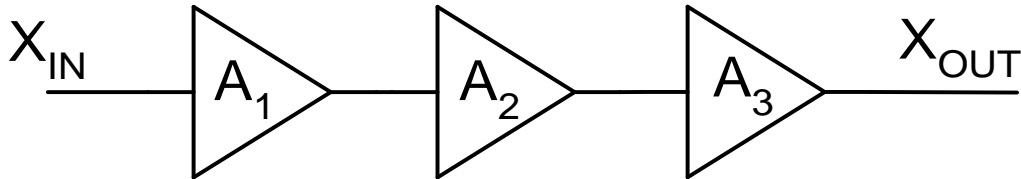

$$\frac{X_{OUT}}{X_{IN}} = A_1 A_2 A_3$$

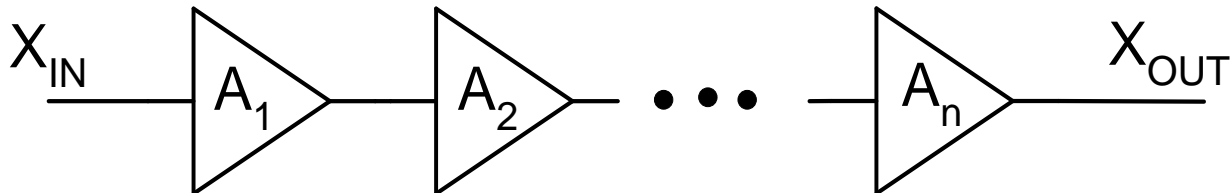

$$\frac{X_{OUT}}{X_{IN}} = \prod_{i=1}^n A_i$$



Gain can be easily increased to almost any desired level !

Increasing Gain by Cascading

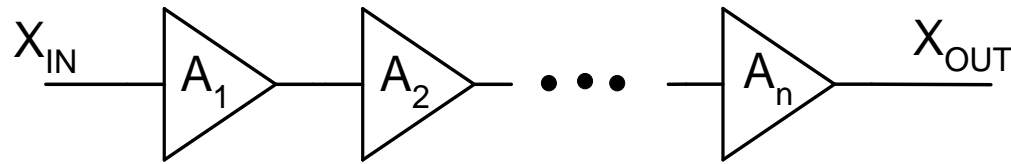

$$\frac{X_{OUT}}{X_{IN}} = \mathbf{A} = \frac{\prod_{i=1}^n A_{0i}}{\prod_{k=1}^n \left(\frac{s}{\tilde{p}_k} + 1 \right)}$$



Assume for case of an example that all stages are identical with $A_{0k}=A_0$ and $\tilde{p}_k = \tilde{p} = -p$

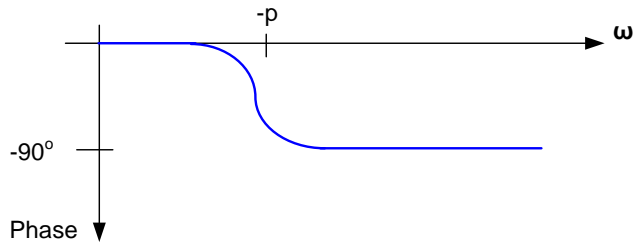
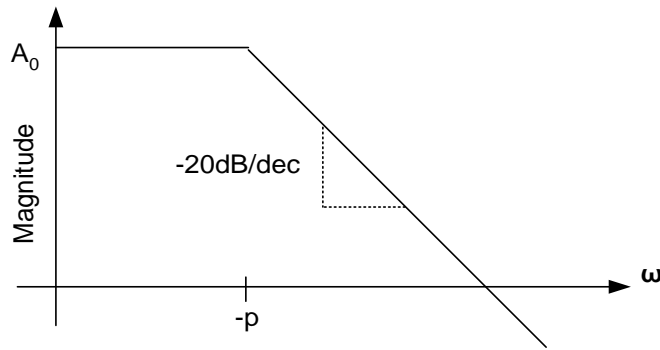

(if inverting gain, phase will decrease from -180° to -270°)

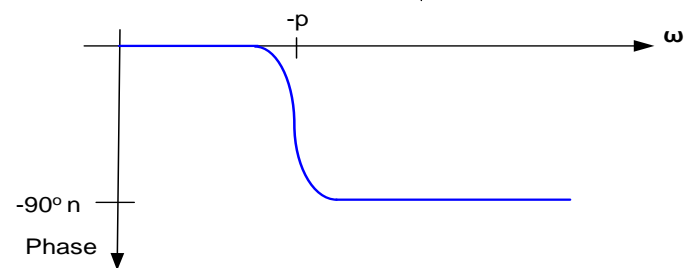
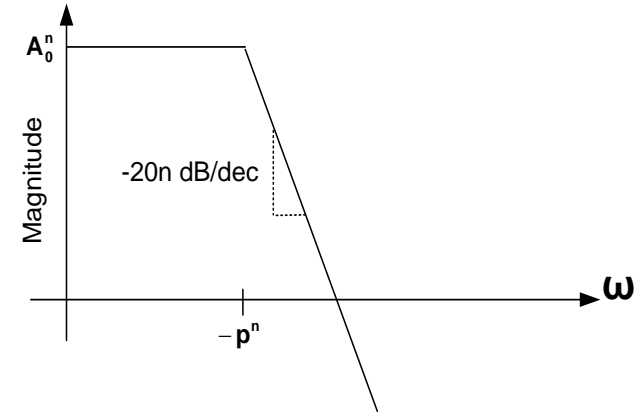

- Much larger gain
- Much larger GB
- Much steeper gain transition
- Much more phase shift

Feedback Amplifier Representation

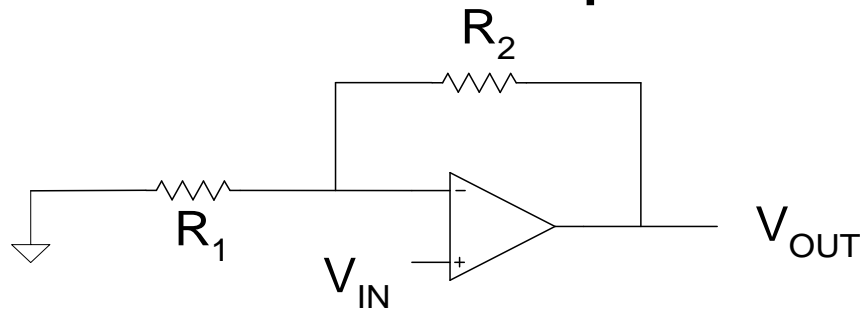

$$\frac{V_{OUT}}{V_{IN}} = \frac{1 + \frac{R_2}{R_1}}{1 + \frac{\left(1 + \frac{R_2}{R_1}\right)}{A}}$$

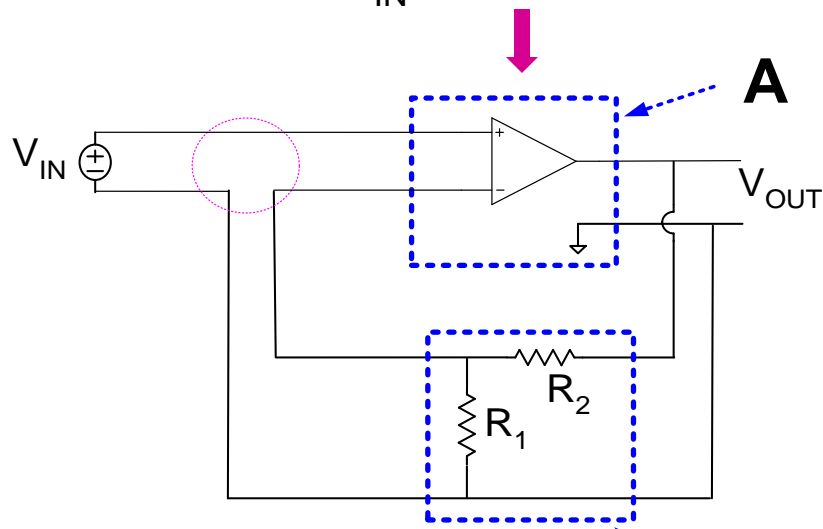

$$\beta = \frac{R_1}{R_1 + R_2}$$

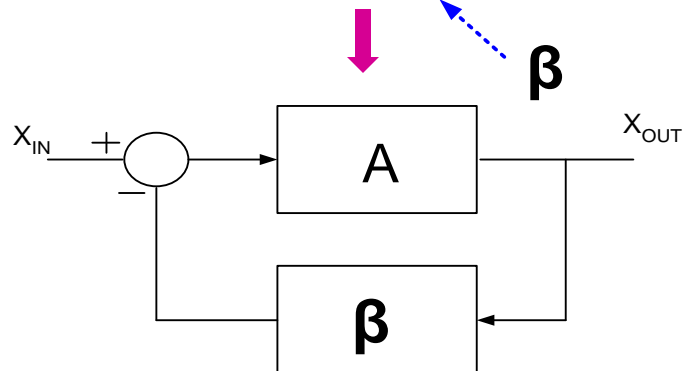

$$A_{FB} = \frac{A}{1 + A\beta} = \frac{\beta^{-1}}{1 + \frac{\beta^{-1}}{A}} = \frac{1 + \frac{R_2}{R_1}}{1 + \frac{\left(1 + \frac{R_2}{R_1}\right)}{A}}$$

Though other feedback configurations may not be so easily decomposed, concepts are similar

Frequency Response of Feedback Amplifier

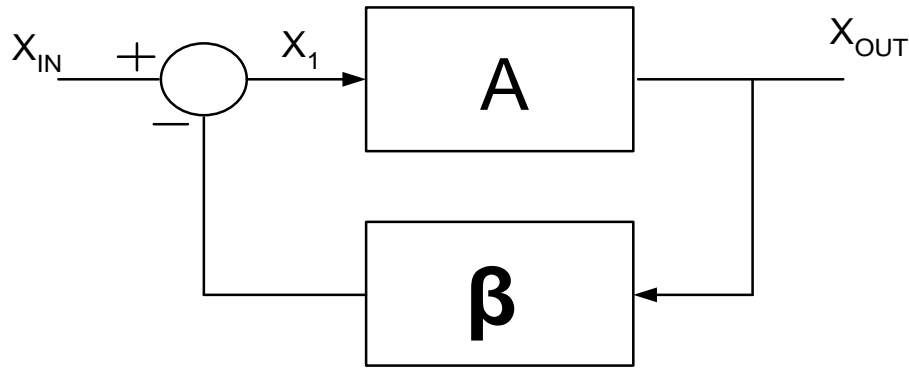

Consider the special case where A is the cascade of n identical stages

$$\frac{X_{OUT}}{X_1} = A = \frac{\prod_{k=1}^n A_{0k}}{\prod_{k=1}^n \left(\frac{s}{\tilde{p}_k} + 1 \right)} = \frac{A_0^n}{\left(\frac{s}{\tilde{p}} + 1 \right)^n}$$

$$A_{FB} = \frac{A}{1 + A\beta} = \frac{A_0^n}{\left(\frac{s}{\tilde{p}} + 1 \right)^n + \beta A_0^n}$$

How do we determine how the amplifier is performing from A_{FB} ?

Review of Basic Concepts

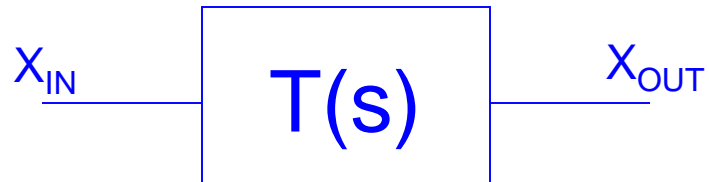

If $T(s) = \frac{N(s)}{D(s)}$ is the transfer function of a linear system

Roots of $N(s)$ are termed the zeros

Roots of $D(s)$ are termed the poles

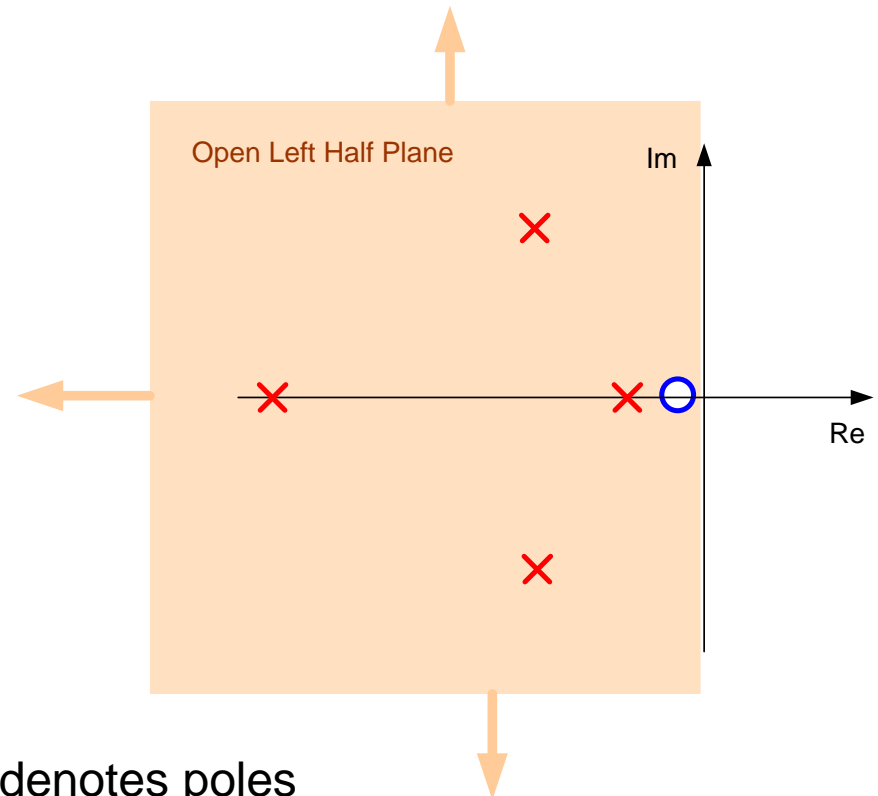

X denotes poles
O denotes zeros

Review of Basic Concepts

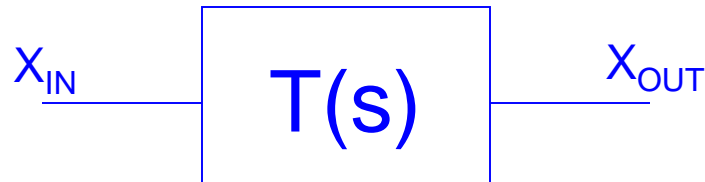

If $T(s) = \frac{N(s)}{D(s)}$ is the transfer function of a linear system

Stability

Definition: A linear system is BIBO stable if for any bounded input, the output is also bounded

BIBO: Bounded-Input Bounded-Output

- The term “stable” and the term “BIBO stable” are used interchangeably
- The amplifier community and the linear analog circuits community invariably use the term “stable”
- Slight variants of the definition of stability are common but for this course minor nuances in the definition of stability are of no concern and the concepts are identical and inherent

Review of Basic Concepts

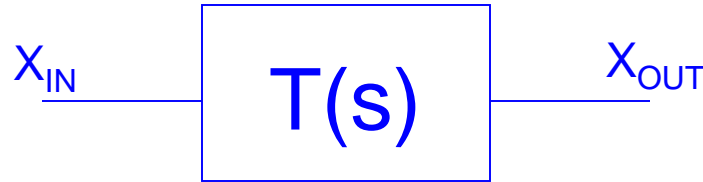

If $T(s) = \frac{N(s)}{D(s)}$ is the transfer function of a linear system

Roots of $N(s)$ are termed the zeros

Roots of $D(s)$ are termed the poles

Theorem: A linear system is stable iff all poles lie in the open left half-plane

- If a circuit is unstable, the output will either diverge to infinity or oscillate even if the input is set to 0
- A FB amplifier circuit that is not stable is not a useful “stand alone” FB amplifier
- A FB amplifier circuit that is “close” to becoming unstable is not a useful “stand alone” amplifier
- An amplifier circuit that exhibits excessive ringing or gain peaking is not a useful “stand alone” amplifier

Review of Basic Concepts

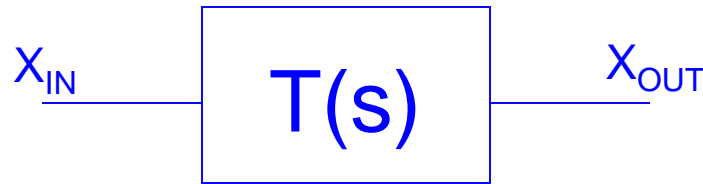

$$T(s) = \frac{N(s)}{D(s)}$$

Theorem: A linear system is stable iff all poles lie in the open left half-plane

Plausibility argument for theorem:

For any input to a linear system, the response in the s-domain can be written as

$$X_{OUT}(s) = X_{IN}(s)T(s) = \sum_{k=1}^n \frac{a_k}{s + \tilde{p}_k} + \sum_{k=1}^h \frac{b_k}{s + \tilde{x}_k}$$

where the terms \tilde{p}_k are the negative of the poles of $T(s)$, the terms \tilde{x}_k are the negative of the roots of the denominator of the excitation and the terms a_k and b_k are the partial fraction expansion coefficients of $X_{OUT}(s)$

If \tilde{p}_k is the negative of any pole, then \tilde{p}_k can be expressed as

$$\tilde{p}_k = -\alpha_k - j\beta_k$$

where α_k is the real part of the pole and β_k is the imaginary part of the pole

$$p_k = -\tilde{p}_k = \alpha_k + j\beta_k$$

Review of Basic Concepts

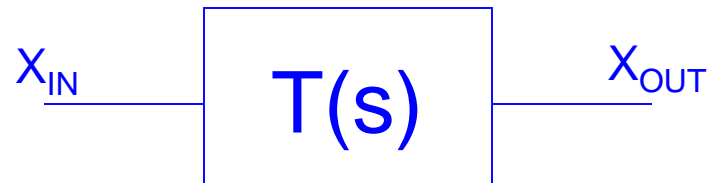

$$T(s) = \frac{N(s)}{D(s)}$$

Theorem: A linear system is stable iff all poles lie in the open left half-plane

Plausibility argument for theorem:

It thus follows that

$$X_{OUT}(t) = \mathcal{L}^{-1}(X_{IN}(s)T(s)) = \sum_{k=1}^n a_k e^{\alpha_k t} e^{j\beta_k t} + \sum_{k=1}^h b_k e^{-j\tilde{\alpha}_k t}$$

Thus, for the output to be bounded for ANY bounded input, must have ALL $\alpha_k < 0$

That is equivalent to saying all poles must lie in the left half-plane

If a pole is in the RHP, output for any input (even very small noise) will grow to infinity (as long as linear operation is maintained). If the corresponding $\beta_k=0$, output will latch up. If corresponding $\beta_k \neq 0$, output will be a growing sinusoid (recall Euler's identity $e^{jx} = \cos x + j \sin x$).

Review of Basic Concepts

Theorem: A linear system is stable iff all poles lie in the open left half-plane

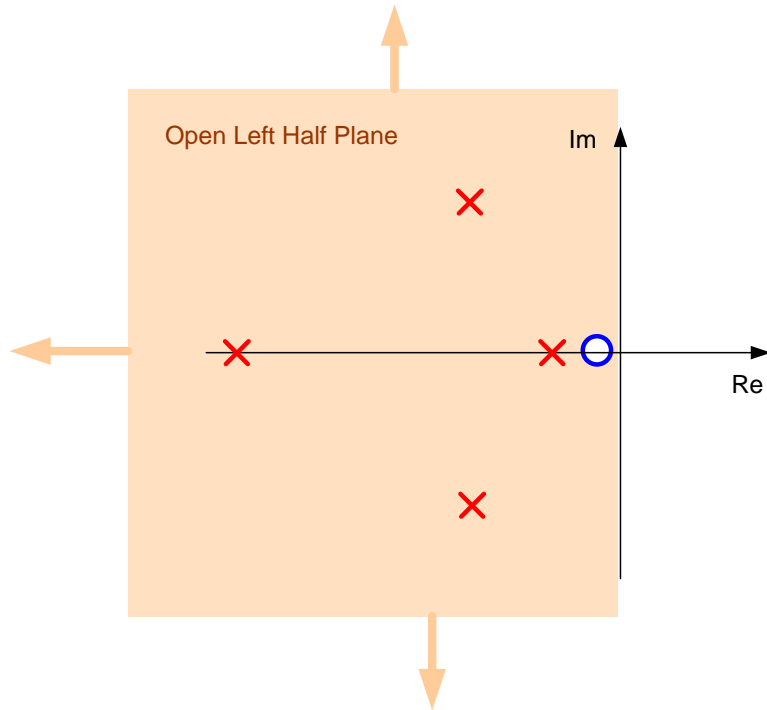

Stable with two negative real axis poles, two LHP complex conjugate poles, and two LHP CC poles

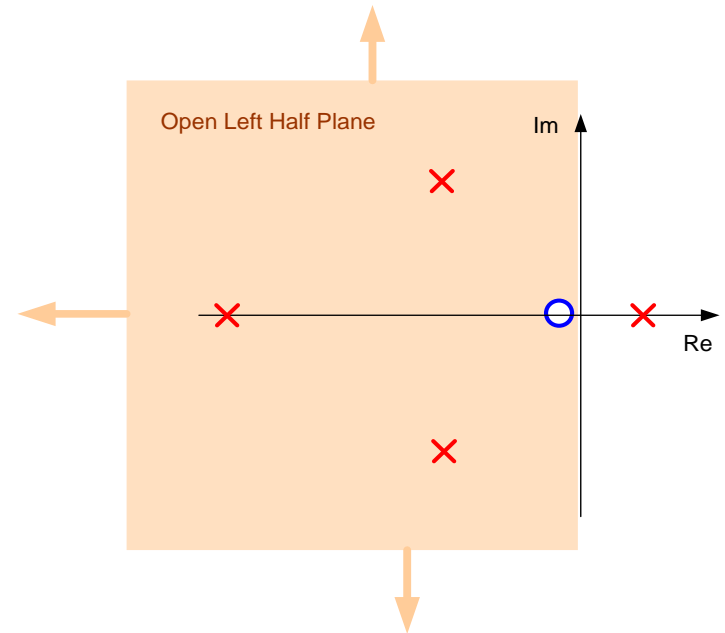

Unstable with positive real axis pole

Review of Basic Concepts

Theorem: A linear system is stable iff all poles lie in the open left half-plane

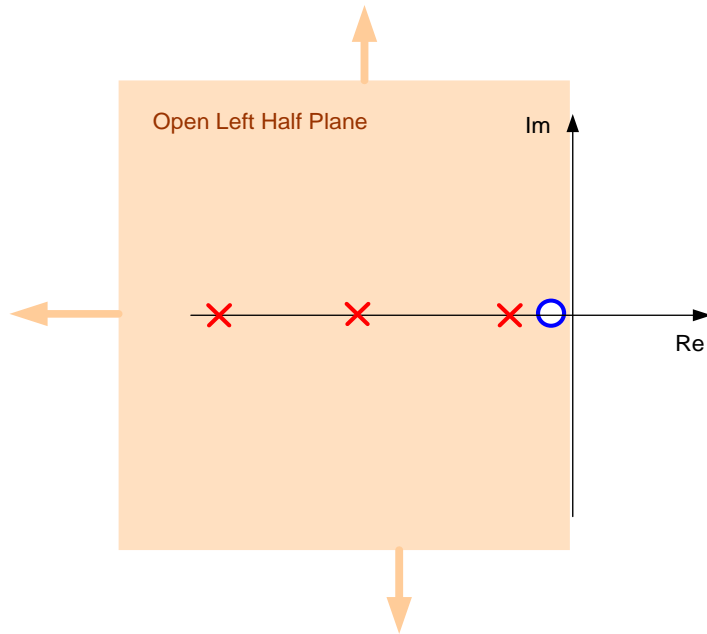

Stable with negative real axis poles

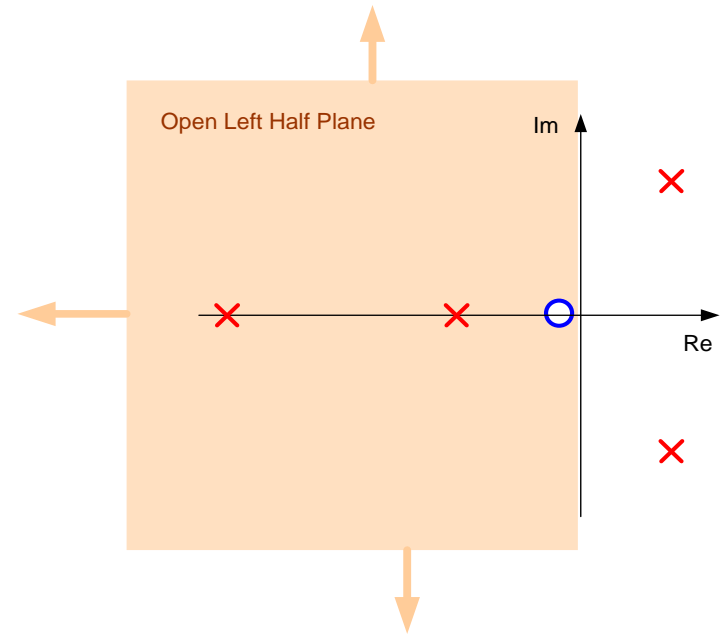

Unstable with cc RHP poles

Review of Basic Concepts

Theorem: A linear system is stable iff all poles lie in the open left half-plane

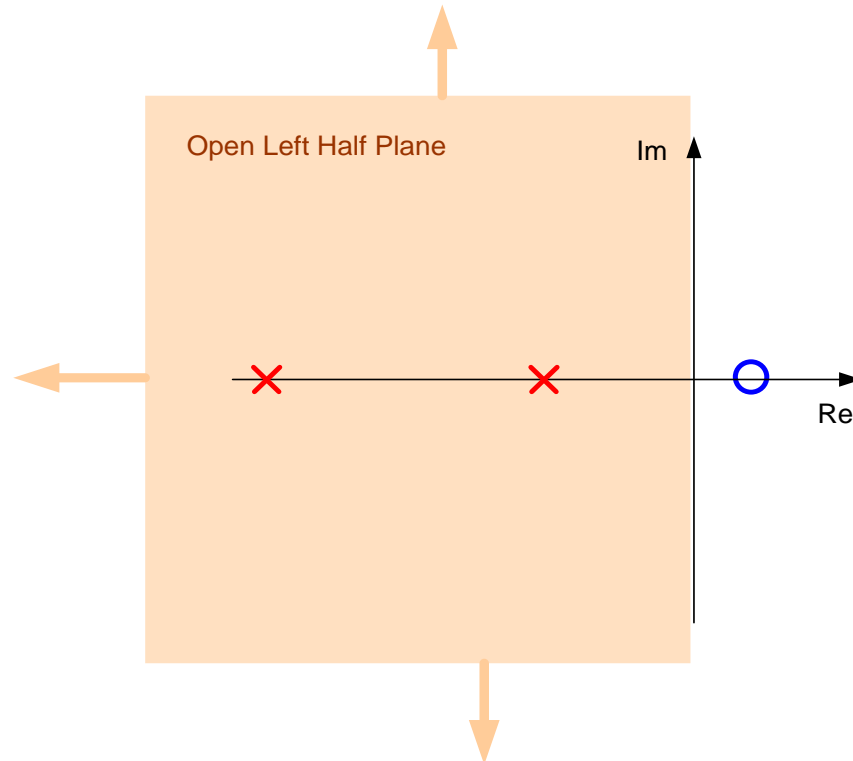

Stable with negative real-axis poles and RHP zero

System zero locations of have no impact on stability

Review of Basic Concepts

Theorem: A linear system is stable iff all poles lie in the open left half-plane

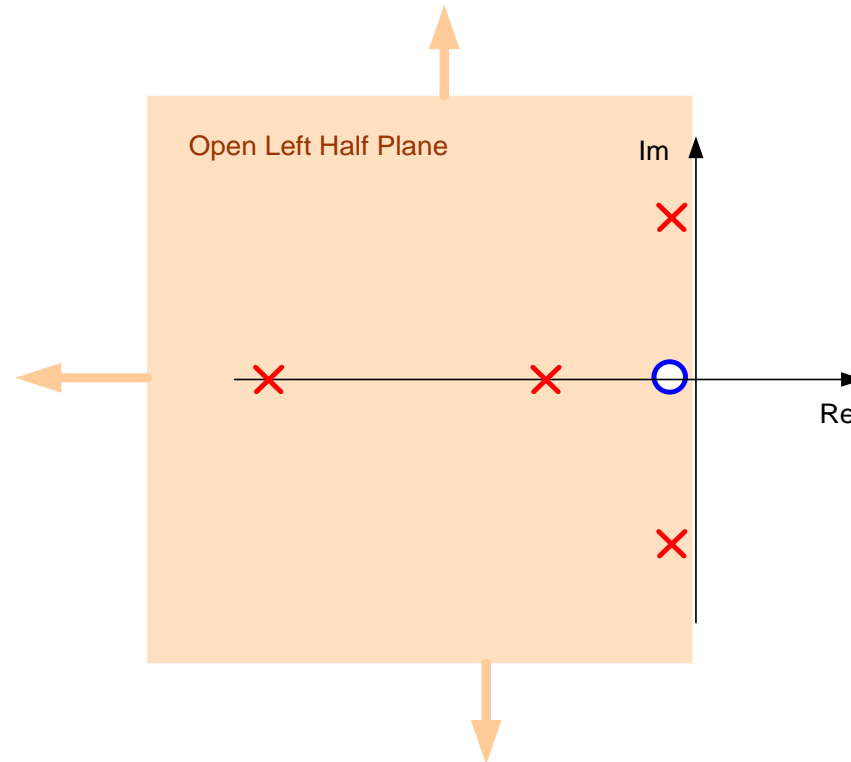

Close to becoming unstable since poles are close (in angular sense) to the RHP

Review of Basic Concepts

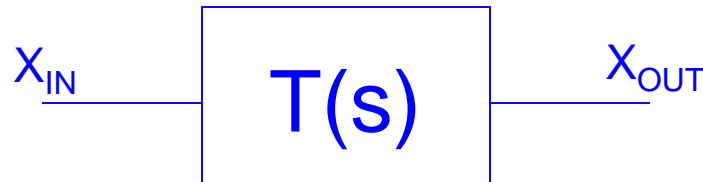

$$T(s) = \frac{N(s)}{D(s)}$$

Theorem: A linear system is stable iff all poles lie in the open left half-plane

What are the practical implications of instability and “close to becoming unstable” ?

$$X_{OUT}(t) = \mathcal{L}^{-1}(X_{IN}(s)T(s)) = \sum_{k=1}^n a_k e^{\alpha_k t} e^{j\beta_k t} + \sum_{k=1}^h b_k e^{-j\tilde{\alpha}_k t}$$

If a pole is in the RHP (i.e. $\alpha_k > 0$) output for any input (even very small noise) will grow to infinity (as long as linear operation is maintained). If the corresponding $\beta_k=0$, output will latch up. If corresponding $\beta_k \neq 0$, output will be a growing sinusoid

If a pole off the real axis is close to the imaginary axis (i.e. “close to becoming unstable”), the output envelope defined by $e^{\alpha_k t}$ for any input will decay very slowly (“ring”)

Consider Again the Frequency Response of a Feedback Amplifier with identical gain stages

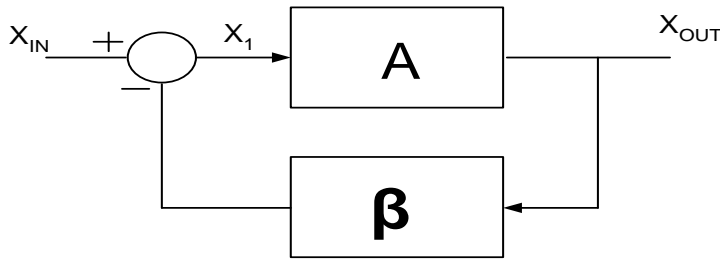

$$A_k = \frac{A_0 \tilde{p}}{s + \tilde{p}}$$

$$A = \prod_{i=1}^n A_k$$

$$A_{FB} = \frac{A_0^n}{\left(\frac{s}{\tilde{p}} + 1\right)^n + \beta A_0^n}$$



Example: Assume $n=3$ and $\beta A_0^3 \gg 1$

$$A_k = \frac{A_0 \tilde{p}}{s + \tilde{p}}$$

$$A = \prod_{i=1}^3 A_k = A_0^3$$

$$A_{FB} = \frac{A}{1 + A\beta} = \frac{A_0^3}{\left(\frac{s}{\tilde{p}} + 1\right)^3 + \beta A_0^3}$$

The poles with feedback (obtained by setting denominator of $A_{FB}(s)$ to 0), p_F , are given by

$$p_F = \left((-1)^{1/3} \beta^{1/3} A_0 - 1 \right) \tilde{p} \underset{\beta A_0^3 \gg 1}{\approx} (-1)^{1/3} \beta^{1/3} A_0 \tilde{p}$$

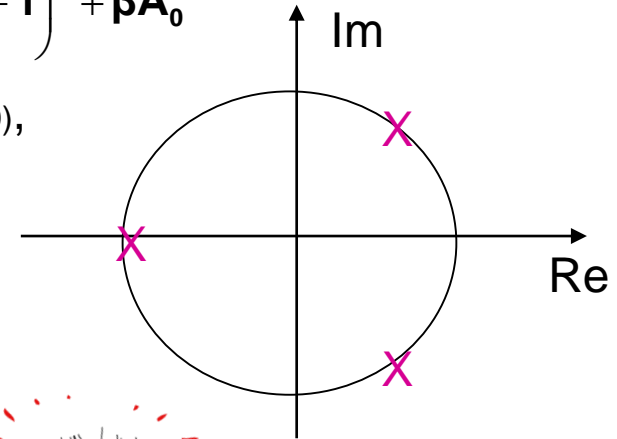

Note this amplifier is unstable !!!

Routh-Hurwitz Stability Criteria:

A third-order polynomial $s^3+a_2s^2+a_1s+a_0$ has all poles in the LHP iff all coefficients are positive and $a_1a_2>a_0$

- Very useful in amplifier and filter design
- Can easily determine if poles in LHP without finding poles
- But tells little about how far in LHP poles may be
- RH exists for higher-order polynomials as well

Consider Again the Frequency Response of Feedback Amplifier

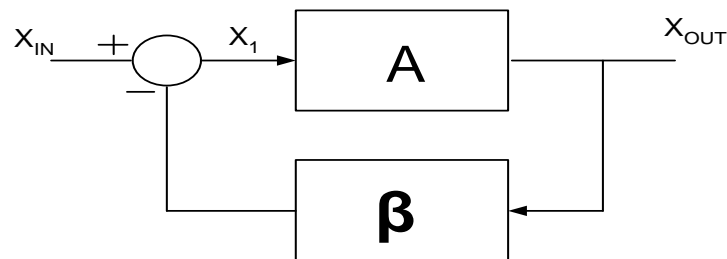

$$A_k = \frac{A_0 \tilde{p}}{s + \tilde{p}}$$

Example: If $n=3$ and stages are identical

$$A_{FB} = \frac{A}{1 + A\beta} = \frac{A_0^3}{\left(\frac{s}{\tilde{p}} + 1\right)^3 + \beta A_0^3}$$

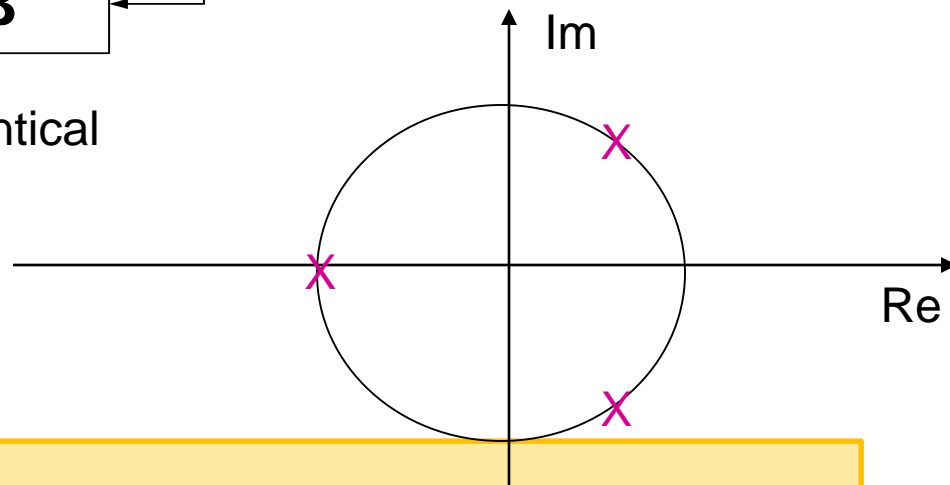

Routh-Hurwitz Stability Criteria:

A third-order polynomial $s^3 + a_2s^2 + a_1s + a_0$ has all poles in the LHP iff all coefficients are positive and $a_1a_2 > a_0$

Consider
$$D_{FB}(s) = \left(\frac{s}{\tilde{p}} + 1\right)^3 + \beta A_0^3 = s^3 \left(\frac{1}{\tilde{p}^3}\right) + s^2 \frac{3}{\tilde{p}^2} + s \frac{3}{\tilde{p}} + (1 + \beta A_0^3)$$

For stability

$$(3\tilde{p})(3\tilde{p}^2) > \tilde{p}^3(1 + \beta A_0^3) \quad \mathbf{8 > \beta A_0^3}$$

Not only is the 3-stage amplifier unstable for practical βA_0^3 , it is far from being stable!

Example:

Assume an amplifier has a transfer function that has a denominator polynomial that can be expressed as

$$D(s) = s^3 + 2ks^2 + 4s + 16$$

Determine the minimum value of k that will result in a stable amplifier

Solution:

Assume an amplifier has a transfer function that has a denominator polynomial that can be expressed as

$$D(s)=s^3+2ks^2+4s+16$$

Determine the minimum value of k that will result in a stable amplifier

Solution: Recall from the RH criteria that all roots of a third-order polynomial of the form $s^3+a_2s^2+a_1s+a_0$ will lie in the LHP provided all coefficients are positive and $a_1a_2 > a_0$

Thus, for the current problem, must have

$$(2k)4 > 16$$

or

$$k > 2$$

Consider Again the Frequency Response of the basic Feedback Amplifier

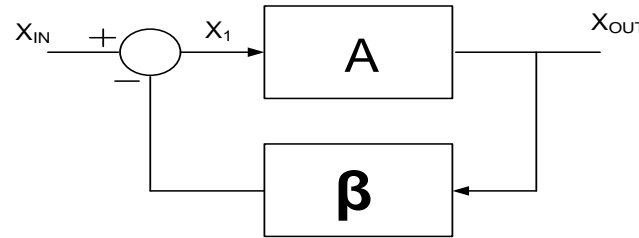

$$A_k = \frac{A_{0k} \tilde{p}_k}{s + \tilde{p}_k} \quad k = 1, 2, 3$$

$$A = \prod_{i=1}^n A_k$$

Example: If $n=3$ and stages are not identical

$$A_{FB} = \frac{A}{1 + A\beta} = \frac{A_{01}A_{02}A_{03}}{\left(\frac{s}{\tilde{p}_1} + 1\right)\left(\frac{s}{\tilde{p}_2} + 1\right)\left(\frac{s}{\tilde{p}_3} + 1\right) + \beta A_{02}A_{03}A_{03}}$$

$$D_{FB}(s) = s^3 + s^2(\tilde{p}_1 + \tilde{p}_2 + \tilde{p}_3) + s(\tilde{p}_1\tilde{p}_2 + \tilde{p}_1\tilde{p}_3 + \tilde{p}_2\tilde{p}_3) + \tilde{p}_1\tilde{p}_2\tilde{p}_3(1 + \beta A_{0TOT})$$

where $A_{0TOT} = A_{01}A_{02}A_{03}$

Consider Again the Frequency Response of Feedback Amplifier

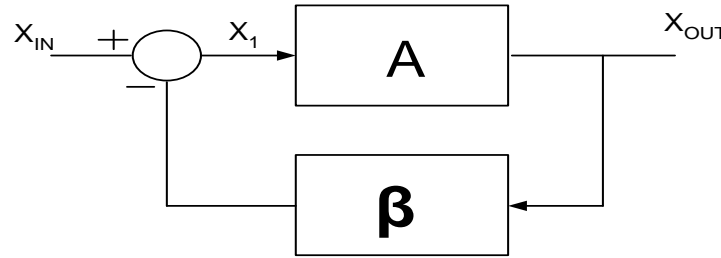

$$A_k = \frac{A_{0k} \tilde{p}_k}{s + \tilde{p}_k} \quad k = 1, 2, 3$$

$$A = \prod_{i=1}^3 A_k$$

Example: If $n=3$ and stages are not identical (cont)

$$D_{FB}(s) = s^3 + s^2(\tilde{p}_1 + \tilde{p}_2 + \tilde{p}_3) + s(\tilde{p}_1\tilde{p}_2 + \tilde{p}_1\tilde{p}_3 + \tilde{p}_2\tilde{p}_3) + \tilde{p}_1\tilde{p}_2\tilde{p}_3(1 + \beta A_{0TOT})$$

Routh-Hurwitz Stability Criteria: (by assuming $1 + \beta A_{0TOT} \cong \beta A_{0TOT}$)

$$(\tilde{p}_1 + \tilde{p}_2 + \tilde{p}_3)(\tilde{p}_1\tilde{p}_2 + \tilde{p}_1\tilde{p}_3 + \tilde{p}_2\tilde{p}_3) > \tilde{p}_1\tilde{p}_2\tilde{p}_3 \beta A_{0TOT}$$

WOLG, assume $\tilde{p}_1 < \tilde{p}_2 < \tilde{p}_3$ and define $\tilde{p}_2 = k_2 \tilde{p}_1$ and $\tilde{p}_3 = k_3 \tilde{p}_1$

Thus the RH criteria can be expressed as

$$(1 + k_2 + k_3)(k_2 + k_3 + k_2k_3) > \beta A_{0TOT}$$

Consider Again the Frequency Response of Feedback Amplifier (cont)

Example: If $n=3$ and stages are not identical

RH criteria:

$$(1 + k_2 + k_3)(k_2 + k_3 + k_2 k_3) > \beta A_{0TOT}$$

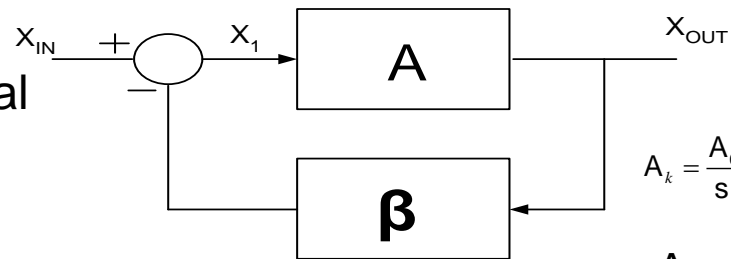

$$A_k = \frac{A_{0k} \tilde{p}_k}{s + \tilde{p}_k} \quad k = 1, 2, 3$$

$$A = \prod_{i=1}^3 A_k$$

Since A_{0TOT} will, in general, be very large for the cascade of 3 stages, a very large pole ratio is required just to maintain stability and an even larger ratio needed to avoid a close to becoming unstable situation

Practically it is difficult to obtain such a large spread in the bandwidth of the amplifiers

Problem can be viewed as one of accumulating too much phase shift before gain drops to an acceptable value

For many years there was limited commercial use of the cascade of three amplifiers (each with gain) in the design of op amps though some academic groups have worked on this approach with minimal practical success

In recent years, industry is looking at ways to “compensate” amplifiers to work with 3 (or more) high gain stages due to low headroom and shrinking g_m/g_o ratios

Similar implications on amplifier even if not a basic voltage feedback amplifier

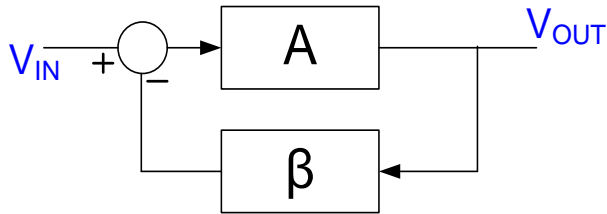
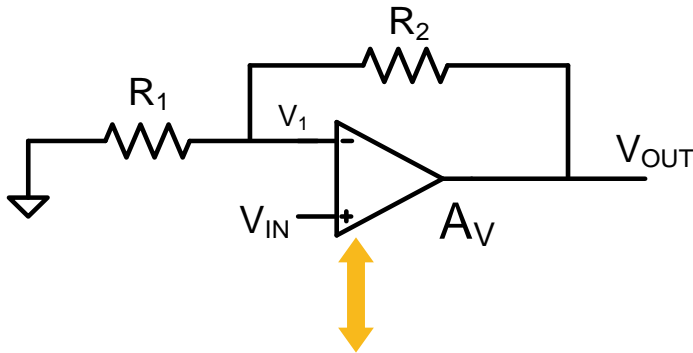

$$A_{VF} = \frac{V_{OUT}}{V_{IN}} = \frac{1 + \frac{R_2}{R_1}}{1 + \frac{1}{A_V} \left(1 + \frac{R_2}{R_1} \right)}$$

$$\beta = \frac{R_1}{R_2 + R_1}$$

$$A_{VF} = \frac{V_{OUT}}{V_{IN}} = \frac{A_V}{1 + \beta A_V}$$

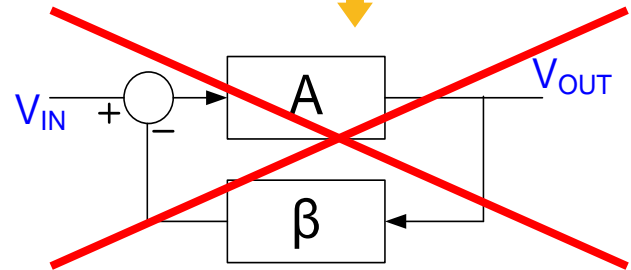
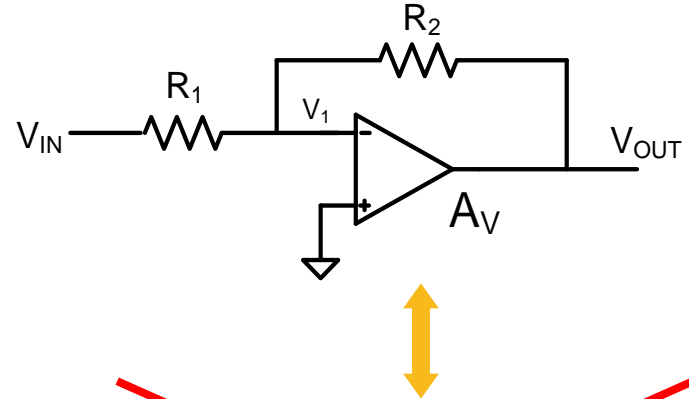

$$A_{VF} = \frac{V_{OUT}}{V_{IN}} = \frac{-\frac{R_2}{R_1}}{1 + \frac{1}{A_V} \left(1 + \frac{R_2}{R_1} \right)}$$

$$\beta = \frac{R_1}{R_2 + R_1}$$

$$A_{VF} = \frac{V_{OUT}}{V_{IN}} = \frac{A_V}{1 + \beta A_V}$$

Similar implications on amplifier even if not a basic voltage feedback amplifier

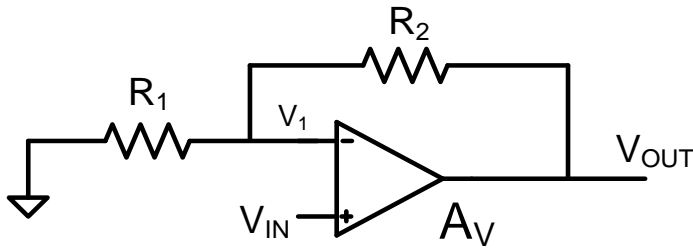

$$A_{VF} = \frac{V_{OUT}}{V_{IN}} = \frac{1 + \frac{R_2}{R_1}}{1 + \frac{1}{A_V} \left(1 + \frac{R_2}{R_1} \right)}$$

$$A_{VF} = \frac{V_{OUT}}{V_{IN}} = \frac{A_V}{1 + A_V \left(\frac{R_1}{R_2 + R_1} \right)}$$

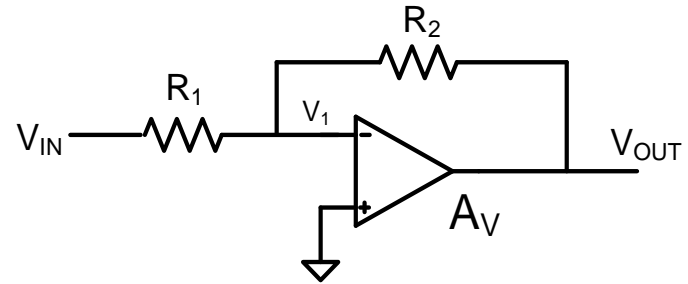

$$A_{VF} = \frac{V_{OUT}}{V_{IN}} = \frac{-\frac{R_2}{R_1}}{1 + \frac{1}{A_V} \left(1 + \frac{R_2}{R_1} \right)}$$

$$A_{VF} = \frac{V_{OUT}}{V_{IN}} = \frac{A_V \left(\frac{-R_2}{R_1} \right)}{1 + A_V \left(\frac{R_1}{R_2 + R_1} \right)}$$

These circuits have

- same β
- same dead network
- same characteristic polynomial
- same poles
- different numerators in A_{VF} (different zeros for some A_V)

$$\beta = \frac{R_1}{R_2 + R_1}$$

$$D(s) = 1 + A\beta \quad (\text{expressed as polynomial})$$

Thus same stability issues !

Example: Determine the dc open-loop gain, dc closed-loop gain, the open-loop poles, the open-loop zeros, the closed-loop poles, the closed-loop zeros, and the characteristic polynomial if

$$A(s) = 10^7 \frac{s+2}{(s+10)(s+1000)}$$

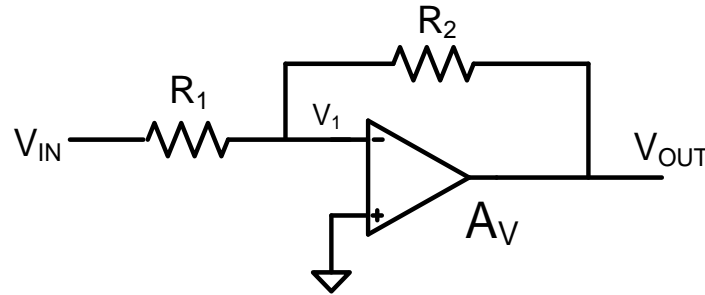

Example: Determine the dc open-loop gain, dc closed-loop gain, the open-loop poles, the open-loop zeros, the closed-loop poles, the closed-loop zeros, and the characteristic polynomial if

$$A(s) = 10^7 \frac{s+2}{(s+10)(s+1000)}$$

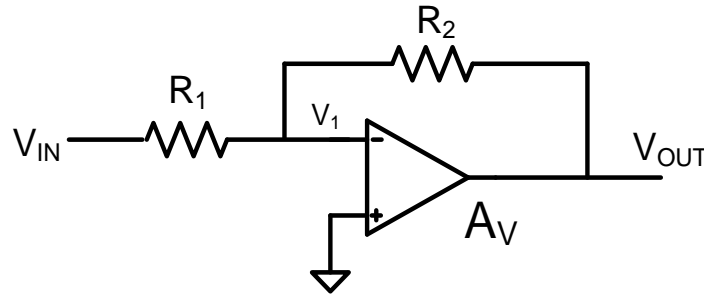

$$A_{OL} =$$

Open-loop zeros =

Open-loop poles =

Example: Determine the dc open-loop gain, dc closed-loop gain, the open-loop poles, the open-loop zeros, the closed-loop poles, the closed-loop zeros, and the characteristic polynomial if

$$A(s) = 10^7 \frac{s+2}{(s+10)(s+1000)}$$

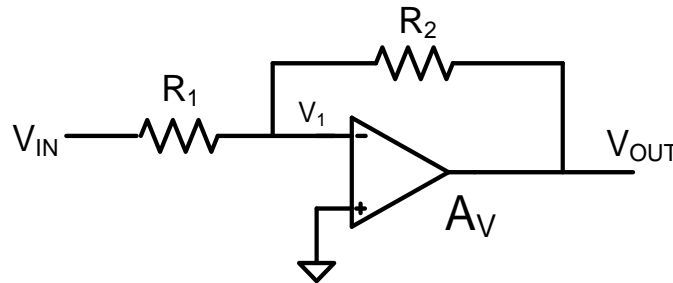

$$A_{VF} = \frac{V_{OUT}}{V_{IN}} = \frac{-\frac{R_2}{R_1}}{1 + \frac{1}{A_V} \left(1 + \frac{R_2}{R_1} \right)}$$

$$\beta = \frac{R_1}{R_2 + R_1}$$

$$A_{VF} = \frac{V_{OUT}}{V_{IN}} = \frac{-\frac{R_2}{R_1}}{1 + \frac{(s+10)(s+1000)}{10^7 \beta (s+2)}}$$

$$A_{VF} = \frac{V_{OUT}}{V_{IN}} = \frac{-\frac{R_2}{R_1} 10^7 \beta (s+2)}{(s+2) 10^7 \beta + (s+10)(s+1000)}$$

Example: Determine the dc open-loop gain, dc closed-loop gain, the open-loop poles, the open-loop zeros, the closed-loop poles, the closed-loop zeros, and the characteristic polynomial if

$$A(s) = 10^7 \frac{s+2}{(s+10)(s+1000)}$$

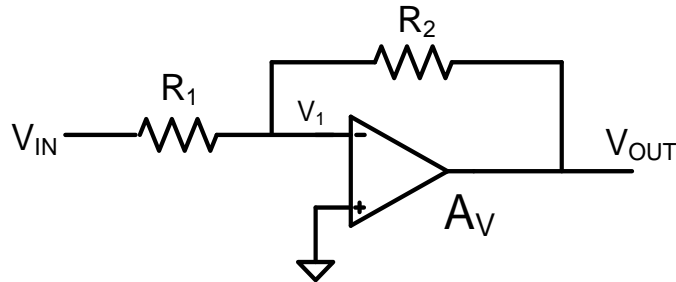

$$A_{VF} = \frac{V_{OUT}}{V_{IN}} = \frac{-\frac{R_2}{R_1} 10^7 \beta (s+2)}{(s+2) 10^7 \beta + (s+10)(s+1000)}$$

$$D_{FB}(s) = (s+2) 10^7 \beta + (s+10)(s+1000)$$

In integer-monic form:

$$D_{FB}(s) = s^2 + s(10+1000+10^7 \beta) + 2 \cdot 10^7 \beta$$

$$A_{OF} =$$

Closed-loop zeros =

Closed-loop poles =

Example: Determine the dc open-loop gain, dc closed-loop gain, the open-loop poles, the open-loop zeros, the closed-loop poles, the closed-loop zeros, and the characteristic polynomial if

$$A(s) = 10^7 \frac{s+2}{(s+10)(s+1000)}$$

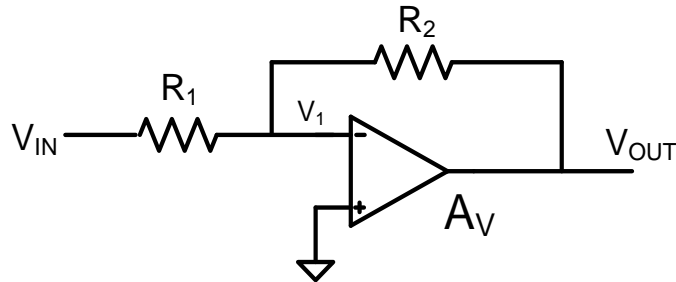

$$A_{VF} = \frac{V_{OUT}}{V_{IN}} = \frac{-\frac{R_2}{R_1} 10^7 \beta (s+2)}{(s+2) 10^7 \beta + (s+10)(s+1000)}$$

$$D_{FB}(s) = (s+2) 10^7 \beta + (s+10)(s+1000)$$

In integer-monic form:

$$D_{FB}(s) = s^2 + s(10+1000+10^7 \beta) + 2 \cdot 10^7 \beta$$

$$A_{0F} = \frac{-\frac{R_2}{R_1} 2 \cdot 10^7 \beta}{2 \cdot 10^7 \beta + 10^4} \stackrel{2 \cdot 10^3 \beta \gg 1}{\cong} -\frac{R_2}{R_1}$$

Closed-loop zeros = -2

Closed-loop poles $\cong -\beta \cdot 10^7$, -2

Cascaded Amplifier Issues

For identical first-order lowpass stage gains

$$A_k = \frac{A_0 \tilde{p}}{s + \tilde{p}} \quad A = \prod_{i=1}^n A_k$$

Summary:

- Three amplifier cascades - for ideally identical stages **$\delta > \beta A_0^3$**
 - seldom used in industry though some recent products use this method !
 - invariably modify A
- Four or more amplifier cascades - problems even larger than for three stages
 - seldom used in industry !

Consider now two amplifiers in cascade

Consider Again the Frequency Response of Feedback Amplifier

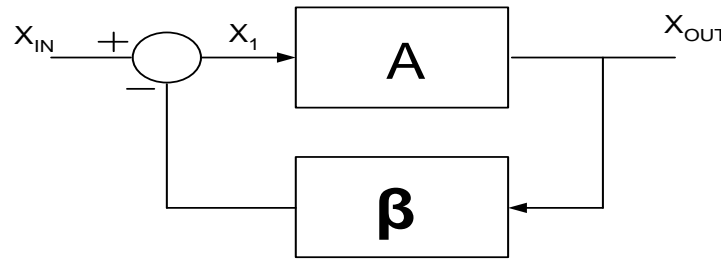

$$A_k = \frac{A_{0k} \tilde{p}_k}{s + \tilde{p}_k}$$

$$k = 1, 2$$

$$A = \prod_{i=1}^2 A_k$$



For two-stage cascade, i.e. $n=2$

$$A_{FB} = \frac{A}{1 + A\beta} = \frac{A_{01}A_{02}}{\left(\frac{s}{\tilde{p}_1} + 1\right)\left(\frac{s}{\tilde{p}_2} + 1\right) + \beta A_{01}A_{02}}$$

If we assume $\tilde{p}_2 \geq \tilde{p}_1$ and thus express $\tilde{p}_2 = k\tilde{p}_1$

The characteristic polynomial can be expressed as

$$D_{FB}(s) = s^2 + s\tilde{p}_1(1+k) + k\tilde{p}_1^2(1 + \beta A_{0TOT})$$

$A_{FB}(s)$ is a second-order lowpass function !

**Note this amplifier is stable !!!!
(at least based upon this analysis)**

Two-stage Cascade (continued)

$$A_k = \frac{A_{0k} \tilde{p}_k}{s + \tilde{p}_k} \quad k = 1, 2$$

$$A = \prod_{i=1}^2 A_k$$

$$D_{FB}(s) = s^2 + s\tilde{p}_1(1+k) + k\tilde{p}_1^2(1 + \beta A_{0TOT})$$

Consider special case of identical stages (i.e. $k=1$)

$$D_{FB}(s) = s^2 + s\tilde{p}_1(2) + \tilde{p}_1^2(1 + \beta A_{0TOT}) \cong s^2 + s\tilde{p}_1(2) + \tilde{p}_1^2(\beta A_{0TOT})$$

thus the poles of the feedback amplifier are located at

$$p_{1,2} = -\tilde{p}_1 \pm \sqrt{\tilde{p}_1^2(1 - \beta A_{0TOT})} \cong -\tilde{p}_1(1 \pm j\sqrt{\beta A_{0TOT}})$$

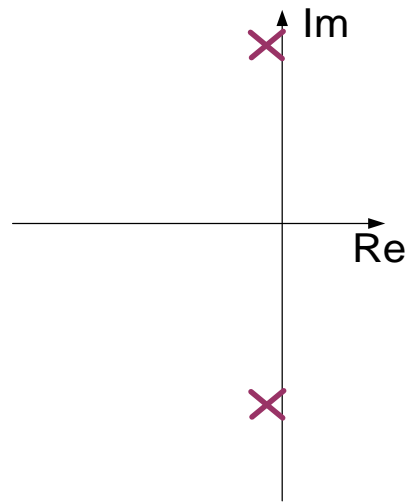

- FB poles are very close to the imaginary axis
- Very highly under-damped
- Not useful as a stand alone amplifier (excessive ringing)
- Other poles (not considered here) will make it unstable

Two-stage Cascade (continued)

$$D_{FB}(s) = s^2 + s\tilde{p}_1(1+k) + k\tilde{p}_1^2(1 + \beta A_{0TOT})$$

$$A_1 = \frac{A_{01} \tilde{p}_1}{s + \tilde{p}_1}$$

$$A_2 = \frac{A_{02} k \tilde{p}_1}{s + k\tilde{p}_1}$$

$$A = \prod_{i=1}^2 A_k$$

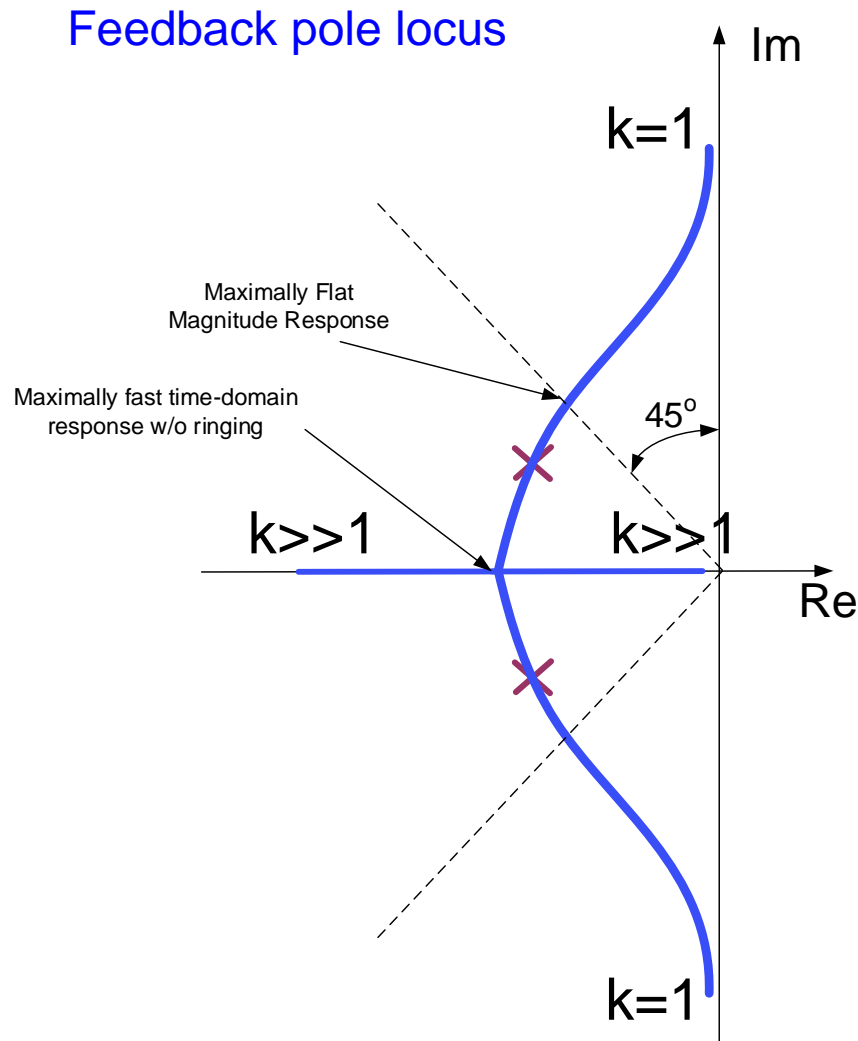

Review of Basic Concepts

Consider a second-order factor of a denominator polynomial, $P(s)$, expressed in integer-monic form

$$P(s) = s^2 + a_1s + a_0$$

Then $P(s)$ can be expressed in several alternative but equivalent ways

$$(s - p_1)(s - p_2)$$

if complex conjugate poles or real axis poles of same sign

$$s^2 + s \frac{\omega_0}{Q} + \omega_0^2$$

$$s^2 + s2\zeta\omega_0 + \omega_0^2$$

if real – axis poles

$$(s - p_1)(s - kp_1)$$

and if complex conjugate poles,

$$(s + \alpha + j\beta)(s + \alpha - j\beta)$$

$$(s + re^{j\theta})(s + re^{-j\theta})$$

Widely used alternate parameter sets:

$$\{ (a_1, a_2) (\omega_0, Q) (\omega_0, \zeta) (p_1, p_2) (p_1, k) (\alpha, \beta) (r, \theta) \}$$

These are all 2-parameter characterizations of the second-order factor and it is easy to map from any one characterization to any other

Review of Basic Concepts

For complex-conjugate poles (of cc zeros)

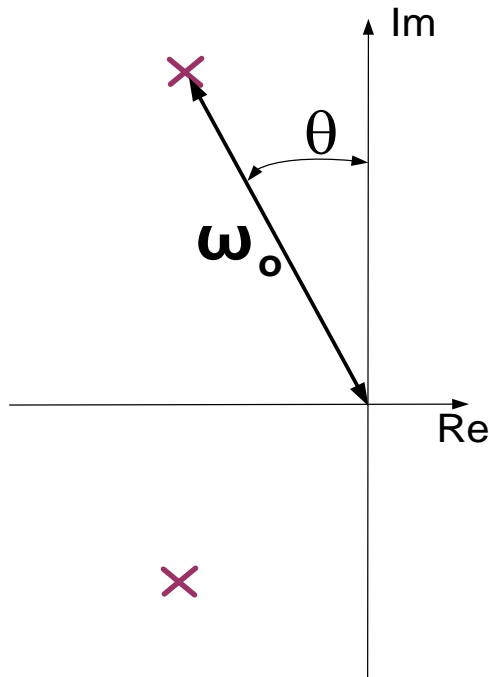

$$s^2 + s \frac{\omega_0}{Q} + \omega_0^2$$

$$\sin\theta = \frac{1}{2Q}$$

ω_0 = magnitude of pole (or zero)

Q determines the angle of the pole (or zero)

Observe: Q=0.5 corresponds to two identical real-axis poles
Q=.707 corresponds to poles making 45° angle with Im axis



Stay Safe and Stay Healthy !

End of Lecture 12